

No job is more important.



Safety Alert

Nº.11 1998

## Incompatible International Electrical Fittings

It has been highlighted recently that refrigerated shipping containers arriving in Australia from overseas are fitted with an international design three-phase electrical plug that is not compatible with Australian electrical outlets.

The international plug is designed with a locating peg that prevents insertion into Australian designed electrical sockets. The locating peg is present to make sure that a connection can't be made between live and neutral or earth pins.

If this locating peg is removed, it is possible to join the Australian socket and international pattern plug. This action, however, makes it possible for a three-phase line to be connected to the earth of the metal container. The container is now 'live' and anyone touching it could be killed (electrocuted).

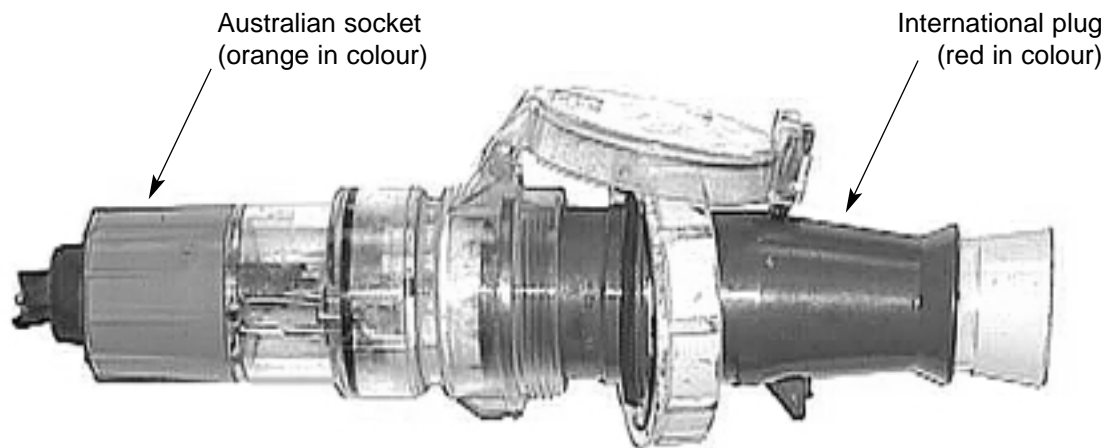

*Dangerous connection. The plug and socket fit together but are obviously not meant to be joined.*

### Contributing Factors

- The need to connect power to international refrigerated shipping containers.
- The incompatibility of international electrical fittings with Australian fittings.
- The modification of plugs that removes the inherent safety of the design.
- The modified plugs look like the unmodified plugs.

## **Recommendations**

- Train workers to recognise the different plugs.
- Provide workers with adequate training on safe working procedures relating to electrical equipment.
- Make sure that workers are provided with a written set of safe working procedures and that they follow them.
- Supervise the actions of the workers so that problems are identified and corrected.
- Electrical connections between international standard refrigerated shipping containers and Australian electrical equipment should only be made by the use of an adaptor assembly that incorporates compatible components. These should consist of an extension cord of an appropriate current carrying capacity fitted with an international extension socket on one end and an Australian approved plug on the other end.
- Make sure that only qualified electricians construct extension cords and make repairs to any electrical equipment.

If you would like further information phone Workplace Standards on  
**1300 366 322** (inside Tasmania) or (03) 6233 7657 (outside Tasmania).

Fax: (03) 6233 8338

Email: [info@wsa.tas.gov.au](mailto:info@wsa.tas.gov.au)

Internet: [www.wsa.tas.gov.au](http://www.wsa.tas.gov.au)

.....  
Steve Hyam, Chief Inspector  
Workplace Standards Authority  
2 November 1998