



Tasmania

# Certificate of Accreditation

## On-Site Waste Water Management System

*This Certificate of Accreditation is hereby issued by the Minister for Justice and Workplace Relations pursuant to Section 59(2) of the Building Act 2000 and Part G2 of the Tasmanian Plumbing Code 2006.*

**System:** **Super-Treat Models: SR480 and SB440 AWTS**  
**Manufacturer:** **Super-Treat Systems Pty. Ltd.**  
**Of:** **286 Princes Highway, South Nowra, NSW, 2541**

*This is to certify that the Super-Treat Modes SR 480 and SB 440 as described in Schedule 1, have been accredited as an on-site waste water management system for use in a single domestic premises in Tasmania. This accreditation is subject to the conditions of accreditation and permitted uses specified in Schedule 2, and in accordance with the Tasmanian Plumbing Code 2006.*

**L. Mark Smith**

*Director, Building Control  
delegate of the Minister for Justice and Workplace Relations*

**Date of Issue: 7 March 2007**

**Certificate No: BSR0384/2007**

**This Certificate of Accreditation is valid until 7 March 2012**

# SCHEDULE 1: System Specification

## Super-Treat SB440 and SR480 Aerated Wastewater Treatment Systems (AWTS)

### General Description

The Super-Treat SB440 and SR480 Aerated Wastewater Treatment Systems (AWTS) are designed to treat and disinfect 200 litres of domestic wastewater per person per day. The systems consist of primary (anaerobic) settlement tanks (PST) to reduce Biochemical Oxygen Demand and Suspended Solids. The secondary aeration tank includes 500 m<sup>2</sup> submerged fixed film growth media. The clarifier collects excess activated sludge and returns it to the PST inlet while maintaining the aeration tank at a constant level. The small amount of effluent being returned with the sludge ensures that an amount of food is always displaced from the PST to the secondary tank during periods of no flow. The aeration cycle is controlled by a time clock and has 2 x 3 hour 'off' periods a day to facilitate anoxic cycles, which nitrify & denitrify the zoogloal growth.

The systems may be retrofitted to existing septic tanks provided the tanks have a minimum design capacity of 3000 litres and comply with AS/NZS 1546.1.

### **Super-Treat SB440**

The SB440 10-EP system is accredited for domestic wastewater flows up to 2000 litres/day with an organic load not exceeding 600gms BOD/day. The SB440 is contained in a vertical axis type cylindrical precast concrete septic tank. The normal operational water level in the system is 1100 mm. The system consists of:

- A primary treatment tank with a capacity of 3400 litres;
- A secondary treatment tank with an operating capacity of 2880 litres containing:
  - An aeration chamber with a total capacity of 2087 litres;
  - A clarifier chamber with a capacity of 285 litres;
  - A chlorine contact chamber with a capacity of 155 litres;
  - An irrigation pump well with a capacity of 55 litres;
- A chlorine disinfection unit installed on the outlet of the clarifying chamber;
- Aeration and agitation in the aeration chamber is provided by venturi air injection and mixing system through a submersible Orange model SP213 pump; and
- A submersible Orange model SP213 (10 metre head) irrigation pump.

### **Super-Treat SB480**

The SR480 8-EP system is accredited for domestic wastewater flows up to 1600 litres/day with organic load not exceeding 600gms BOD/day. SB480 AWTS is contained in a vertical axis type cylindrical tapered injection moulded polypropylene septic tank. The normal operational water level in the SR480 is 1100 mm. The system consists of:

- A primary treatment tank with a capacity of 3000 litres;
- A secondary treatment tank with a capacity of 2450 litres containing:
  - An aeration chamber with a total capacity of 2087 litres;
  - A clarifier chamber with a capacity of 285 litres;
  - A chlorine contact chamber with a capacity of 155 litres;
  - An irrigation pump well with a capacity of 55 litres;
- A chlorine disinfection unit installed on the outlet of the clarifying chamber;
- Aeration and agitation in the aeration chamber is provided by venturi air injection and mixing system through a submersible Orange model SP213 pump; and
- A submersible Orange model SP213 (10 metre head) irrigation pump.

## Schedule 2: Conditions of Accreditation

### Definitions

In this schedule:

**AS/NZS 1547** means the Joint Australian/New Zealand Standard “AS/NZS 1547:2000 On-site domestic-wastewater management”;

**AS/NZS 1546.1** means the Joint Australian/New Zealand Standard “AS/NZS 1546.1:1998 On-site domestic wastewater treatment units, Part 1: Septic tanks”;

**AS/NZS 3000** means the Joint Australian/New Zealand Standard “AS/NZS 3000:2000 Wiring rules”;

**AS/NZS 5667** means the Joint Australian/New Zealand Standard “AS/NZS 5667.1:1998 Water quality – Sampling, Part 1: Guidance on the design of sampling programs, sampling techniques and preservation and handling of samples”;

**BOD<sub>5</sub>** means “5-day Biochemical Oxygen Demand”;

**Council** means “the Municipal Council having jurisdiction”;

**Commissioned** means “when the test results from a NATA Certified Laboratory show that the water quality requirements for the AWTS have been met and all pre-commissioning tests have been carried out in accordance with AS/NZS 1547 on all associated equipment and the irrigation system (where installed)”;

**Designer** means “a person who has a specialty in the area of designing on-site waste water management systems and may include but not be restricted to appropriately trained professional engineers, soil scientists, land surveyors and plumbers”;

**Director** means the Director of Building Control

**EP** means “equivalent persons”

**FC** means faecal coliforms;

**NATA** means “National Association of Testing Authorities”;

**Permit** means “a Permit issued by the council pursuant to section 82 of the *Building Act 2000*”;

**Permit authority** means a person or body authorised for that purpose by the council of the municipal area in which the on-site waste water management system is installed;

**SS** means “Suspended Solids”;

**System** means “Super-Treat SB440 and SR480”

**N** means “Nitrogen”;

**TPC** means the “Tasmanian Plumbing Code 2006”.

## 1.0 General

- 1.1 The system must be supplied, constructed and installed in accordance with the design submitted and accredited by the Department of Justice.
- 1.2 The system must not be installed in a plumbing installation other than in accordance with the conditions of permit issued by the Permit Authority.
- 1.3 The manufacturer must supply the owner and occupier, of each installation, with a user manual setting out the following:
  - (a) the treatment process;
  - (b) procedures to be followed in the event of a system failure;
  - (c) emergency contact number;
  - (d) care, operation, monitoring and maintenance requirements; and
  - (e) inspection and sampling procedures to be followed as part of the on-going monitoring and program required by the Permit Authority.
- 1.4 The systems installation requirements are:
  - (a) SB440: 2000 litres/day with an organic load not exceeding 600 grams BOD/day; and
  - (b) SR480: 1600 litres/day with an organic load not exceeding 480 grams BOD/day.
- 1.5 If the system is retrofitted to existing septic tank, the primary settlement tank (septic tank) must have a minimum design capacity of 3000 litres for both models (manufacturer's requirement).
- 1.6 Where a system is to be retrofitted to an existing septic tank, that tank must be desludged prior to the commissioning of the system.
- 1.7 Any proposed modifications to the system's specified processes, equipment, materials, fittings or manuals must be authorised by the Director and may be subject to additional verification or testing.
- 1.8 The SB480 is authorised for in ground installation only (see 3.5 below).
- 1.9 The system must not be deployed in areas where the annual climatic conditions will allow the effluent in the primary tank to not maintain an average temperature of 12<sup>0</sup> Celsius or greater.
- 1.10 Each unit must be provided with a permanent, clear indelible notice in a prominent position that is readily visible after installation. The notice is to include, as a minimum, the following information:
  - (a) the manufacturer's name or registered mark;
  - (b) model number or designation;
  - (c) the month and year of manufacture;
  - (d) the capacity in litres/week;
  - (e) top load limitations; and

- (f) weight of unit.
- 1.11 The manufacturer must provide the following information to each permit authority where it is intended to install a system in their jurisdiction:
  - (a) Statement of warranty
  - (b) Statement of service life
  - (c) Quality Assurance Certification
  - (d) Installation Manual
  - (e) Service Manual
  - (f) Owner's Manual
  - (g) Service Report Form
  - (h) Engineering Drawings on A3 format
  - (i) Detailed Specifications
  - (j) A4 Plans
  - (k) Certificate of Accreditation and associated Schedules.
- 1.12 The manufacturer is to keep a register of installed systems in Tasmania and be made available to the Director on request.
- 1.13 The Certificate of Accreditation is valid for five (5) years from the date of issue or until withdrawn by the Director.

## **2.0 Waste Water Discharge**

- 2.1 Land application systems used in conjunction with the system must satisfy the relevant requirements of AS/NZS 1547.
- 2.2 Effluent distribution by surface or subsurface irrigation may be permitted where the Permit Authority is satisfied that the application for a permit to install the system has demonstrated that the:
  - (a) effluent can be retained within the authorised land application area;
  - (b) irrigation system has been designed and is capable of being installed and maintained in accordance with AS/NZS 1547;
  - (c) the location of the land application system satisfies the relevant requirements of the *State Policy on Water Quality Management 1997*; and
  - (d) the discharge is capable of satisfying the relevant water quality limits set out in section 5.

## **3.0 Installation and Commissioning**

- 3.1 The installation and operation of the system must comply with the conditions of accreditation and the manufacturers installation requirements.
- 3.2 All plumbing work carried out in connection with the system must satisfy the requirements of the *Building Act 2000, TPC, Tasmanian*

*Plumbing Regulations 2004* and be carried out by a registered plumber with appropriate competencies.

- 3.3 All installations of the system must be installed in accordance with the installation requirements set out in *Appendix A1 – On-site Waste Water Management Systems* of the *TPC*.
- 3.4 All electrical work must be carried out by a licensed electrician and in accordance with relevant provisions of AS/NZS 3000.
- 3.5 The polypropylene tanks are authorised for in ground installation only unless a detailed engineering design is completed to cover the tanks for above or partially above ground installation. The design must provide details for structural integrity of the tanks and details for protection from ultraviolet degradation.
- 3.6 Each installation must be inspected and checked by the designer or the designer's agent. The designer on completion is to certify that the installation has been constructed, installed and commissioned in accordance with its design, the conditions of accreditation and any additional requirements of the Permit Authority.
- 3.7 Where discharging waste water to a land application system by shallow sub-surface or above ground irrigation, a lockable sampling tap or gate valve is to be provided on the outlet pipe to the irrigation system.
- 3.8 A report is to be prepared by the council approved maintenance contractor detailing the inspection of the installation and the results of the commissioning tests and be accompanied by a certificate certifying that the system is operating and performing adequately.
- 3.9 Copies of any report or certificate required by these conditions are to be made available to the Director on request.

#### **4.0 Maintenance**

- 4.1 The systems must be operated and maintained to ensure they perform continuously and without any intervention between inspections carried out by the council approved servicing contractor.
- 4.2 The owner of the system must enter into and maintain a maintenance contract with the council, the manufacturer of the system, or other council approved person.
- 4.3 The owner must enter into an agreement with the council to maintain the maintenance contract where that contract is with the manufacturer of the system or other council approved person.
- 4.4 Maintenance must be carried out at least once every three months in accordance with the conditions of accreditation and the manufacturer's specifications.

- 4.5 Each three (3) monthly service must include a check on all mechanical, electrical and functioning components of the system including:
- (a) Reporting on weather conditions, ambient temperature, effluent temperature and odour;
  - (b) The chlorinator and replenishment of the disinfectant;
  - (c) Pumps, air blower, fan or air venturi;
  - (d) The alarm system;
  - (e) Slime growth on filter media;
  - (f) Operation of sludge return, sludge level and desludging;
  - (g) Water meter reading (where applicable);
  - (h) Trench Operation (Where applicable);
  - (i) The irrigation area, irrigation fittings and filters; and
  - (j) On-site testing for free residual chlorine, pH and dissolved oxygen.
- 4.6 Sampling must be carried out for BOD<sub>5</sub>, SS and FC's, by a council approved person, to verify that the plant is commissioned. The samples are to be tested and reported on by a NATA certified laboratory.
- 4.7 The system is to be deslugged at not greater than 5 yearly intervals and strictly in accordance with the manufacturers recommendations.
- 4.8 The removal and disposal of sludge must satisfy the relevant requirements of the *Tasmanian Biosolids Reuse Guidelines* published by the Department of Primary Industries and Water.

## **5.0 Reporting and On-going Management**

- 5.1 Where any systems have been found not to operate satisfactorily during their service life, and as a result require modification to achieve the required performance requirements, in particular, water quality limits, the installed systems are to be modified accordingly.
- 5.2 Mandatory testing for Free Residual Chlorine is to be carried out, every three months and is to commence 3 months after the plant is commissioned, by using a Lovibond<sup>®</sup> or equivalent quality testing kit. The testing is to coincide with the manufacturers required on-going routine scheduled maintenance program.
- 5.3 In the event of failure to comply with the water quality limits under Section 3, fortnightly sampling for BOD<sub>5</sub>, FC's and Free Residual Chlorine must be carried out until the plant is recommissioned.
- 5.4 The method of preserving and the handling of samples taken from the plant must satisfy the relevant requirements of AS/NZS 5667.
- 5.5 The effluent discharged from the system when tested must not exceed the following water quality limits:
- (a) For all discharges:

Date of issue: 7 March 2007	L. Mark Smith Director, Building Control delegate of Minister for Justice and Workplace Relations
-----------------------------	---

- 90 % of the samples shall have a BOD<sub>5</sub> less than or equal to 20 g/m<sup>3</sup> with no sample greater than 30 g/m<sup>3</sup>.
- 90 % of the samples shall have total SS less than or equal to 30 g/m<sup>3</sup> with no sample greater than 45 g/m<sup>3</sup>.

(b) For surface irrigation

- 90 % of the samples shall have a BOD<sub>5</sub> less than or equal to 20 g/m<sup>3</sup> with no sample greater than 30 g/m<sup>3</sup>.
- 90 % of the samples shall have total SS less than or equal to 30 g/m<sup>3</sup> with no sample greater than 45 g/m<sup>3</sup>.
- The samples taken on each occasion must have a FC count not exceeding a median value of 10 organisms per 100 mL with 80% of the samples containing less than 20 organisms per 100 mL and no sample exceeding 100 organisms per 100 mL.

(b) For above ground irrigation or where required by the permit authority, Free Residual Chlorine concentrations are to be greater than or equal to 0.5 g/ m<sup>3</sup> and less than 2.0 g/m<sup>3</sup>.

5.6 It is recommended that the council cause annual random surveillance for FC's at not less than 25% of the installations at the individual owner's expense. All installations should be monitored over a four-year period.

5.7 Copies of the following reports and certificates must be submitted to the Permit Authority and the owner as soon as practicable after the commissioning of the system and after each scheduled or unscheduled service or inspection for the period specified in the permit:

- (a) the initial plant installation and commissioning report;
- (b) all laboratory analytical test reports; and
- (c) all inspection and maintenance reports accompanied by a certificate referred to in condition 3.8.

**6.0 Permitted uses**

6.1 The effluent is suitable for irrigating garden beds by way of any of the forms of irrigation described in AS/NZS 1547:

- (a) Above ground spray irrigation
- (b) surface drip irrigation; or
- (c) sub-surface drip irrigation covered by mulch which is maintained with a minimum 100 mm cover.

Each of the above forms of irrigation is subject to consent from the permit authority.

Date of issue: 7 March 2007	L. Mark Smith Director, Building Control delegate of Minister for Justice and Workplace Relations
-----------------------------	---

# APPENDIX: 2A – SUPER-TREAT SB480

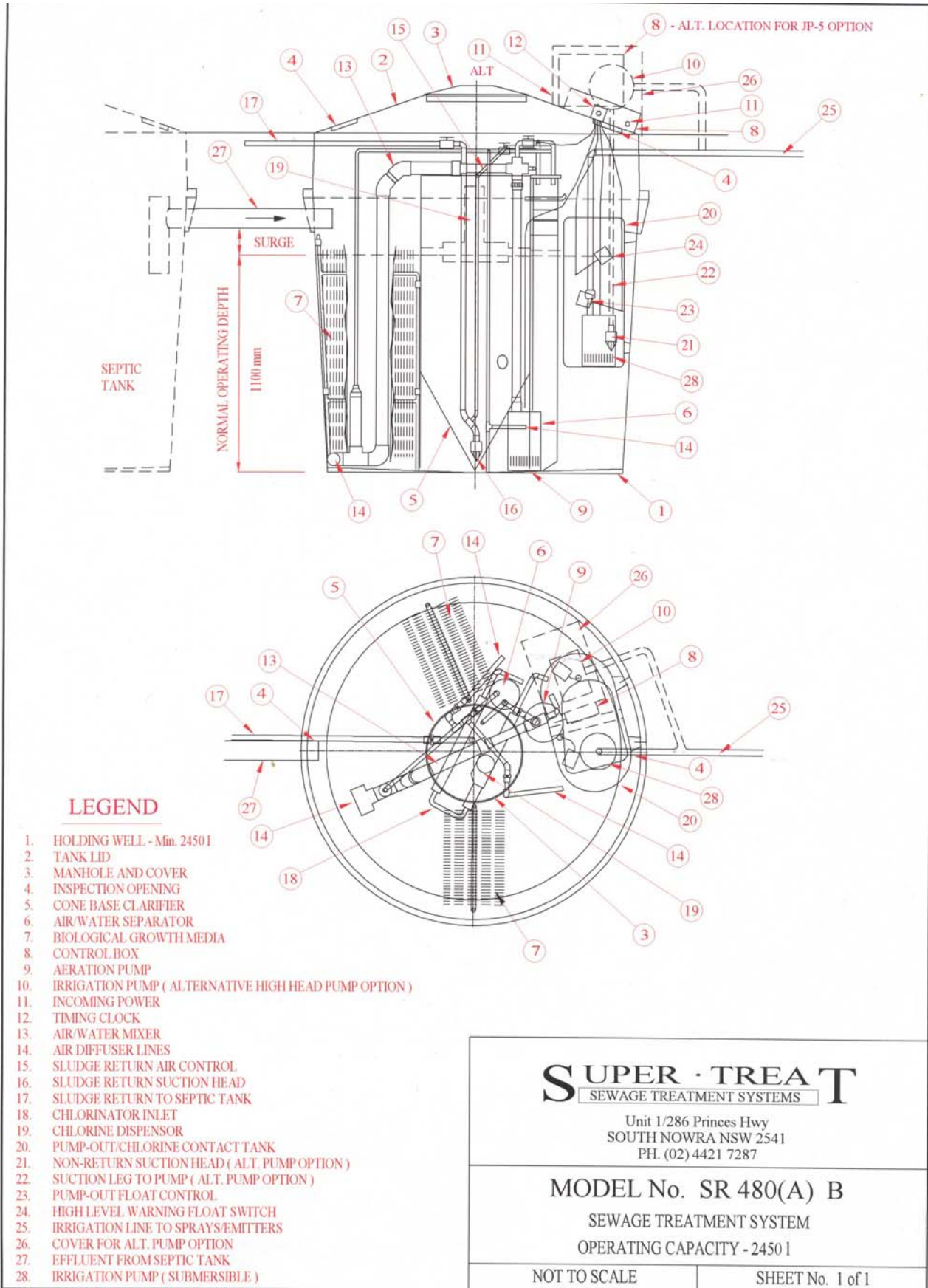

Date of issue: 7 March 2007

L. Mark Smith  
Director, Building Control  
delegate of Minister for Justice and Workplace Relations

# APPENDIX: 2B - SUPER-TREAT SB440

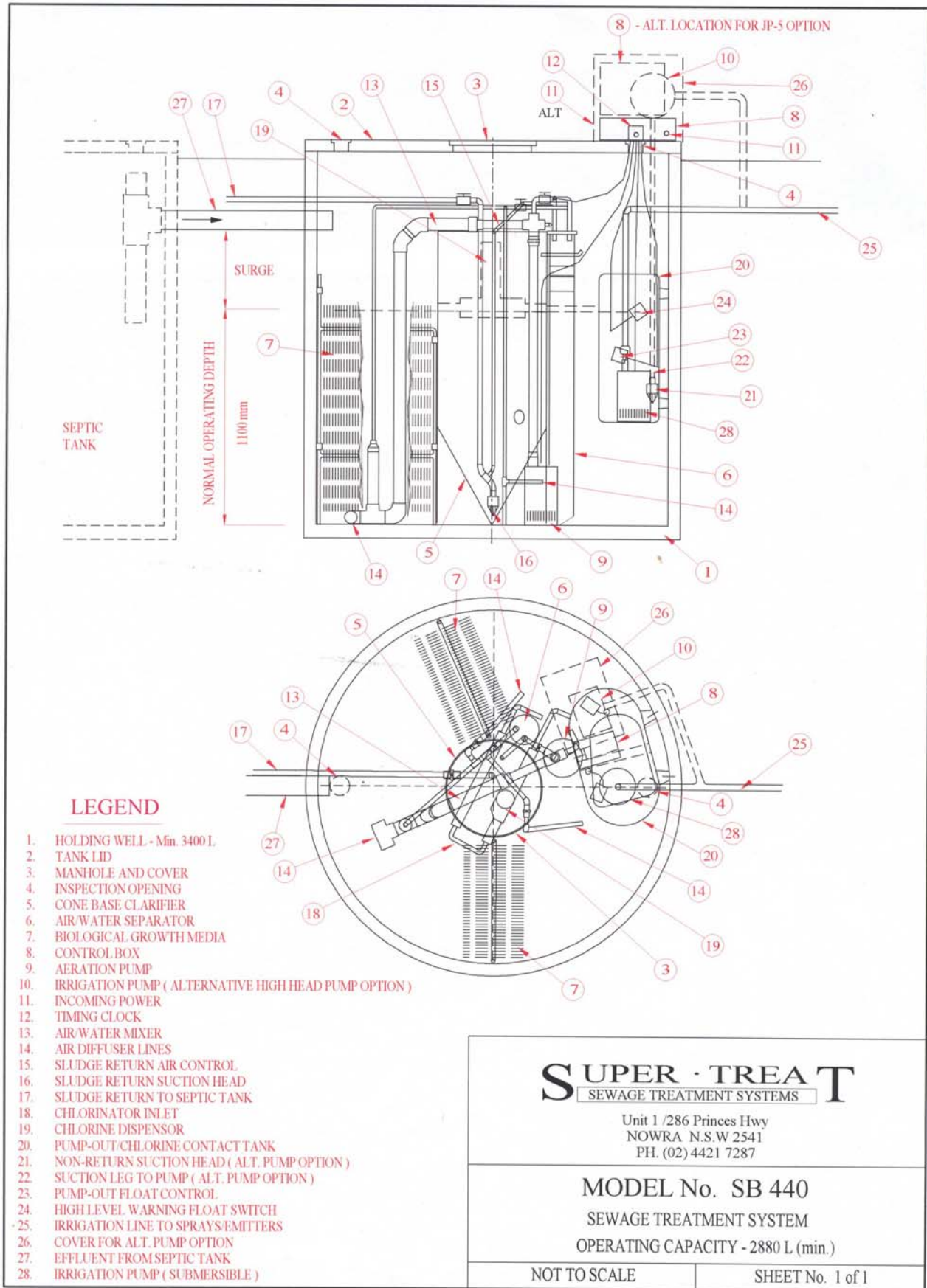

## SUPER-TREAT

SEWAGE TREATMENT SYSTEMS

Unit 1 /286 Princes Hwy  
NOWRA N.S.W 2541  
PH. (02) 4421 7287

**MODEL No. SB 440**

SEWAGE TREATMENT SYSTEM  
OPERATING CAPACITY - 2880 L (min.)

NOT TO SCALE

SHEET No. 1 of 1

Date of issue: 7 March 2007

L. Mark Smith  
Director, Building Control  
delegate of Minister for Justice and Workplace Relations